

**SINGLE SCISSOR TABLES**

Capacity	C Raised Height	B Closed Height	Operation	E x A Platform W x L	E x D O/A W x L	F Handle Height	Wheel Dia	Approx Weight	Reference
300kg	840mm	335mm	Manual Hyd	500 x 840	500x1050	860	125mm	83	SC-300-S-M
300kg	840mm	335mm	Battery Electric	500 x 840	500x1130	860	125mm	130	SC-300-S-E
500kg	900mm	340mm	Manual Hyd	610 x 1030	610x1320	925	125mm	109	SC-500-S-M
500kg	900mm	340mm	Battery Electric	610 x 1030	610x1330	925	125mm	158	SC-500-S-E

**DOUBLE SCISSOR TABLES**

Capacity	C Raised Height	B Closed Height	Operation	E x A Platform W x L	E x D O/A W x L	F Handle Height	Wheel Dia	Approx Weight	Reference
125kg	1420mm	430mm	Manual Hyd	500 x 840	500x1090	860	125mm	100	SC-125-D-M
125kg	1420mm	430mm	Battery Electric	500 x 840	500x1130	860	125mm	147	SC-125-D-E
300kg	1350mm	295mm	Manual Hyd	590 x 840	640x1190	900	150/125	110	SC-300-D-M
450kg	1550mm	295mm	Manual Hyd	610 x 1030	665x1350	910	150/125	143	SC-450-D-M
450kg	1550mm	295mm	Battery Electric	610 x 1030	665x1350	910	150/125	190	SC-450-D-E

**Options**

- Second brake wheel
- Stainless steel top cover
- Plastic roller conveyor top (Increases closed / raised height by 60mm)
- Ball Top
- Bellows safety skirt
- Rubber Mat

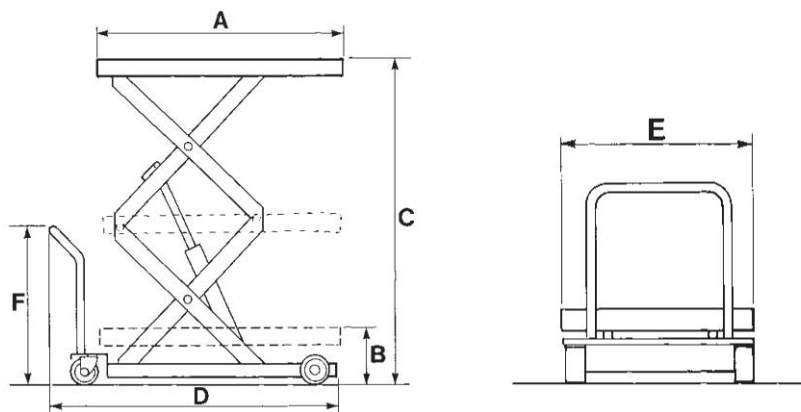

All dimensions are in mm unless otherwise shown